

# ELECTRONIC ROTARY GEAR MOTOR SERIES AB1...SE

## INSTALLATION AND OPERATING INSTRUCTIONS

<b>1</b>	<b>GENERAL FEATURES</b>	<b>2</b>
<b>2</b>	<b>TECHNICAL DATA</b>	<b>2</b>
<b>3</b>	<b>INSTALLATION</b>	<b>3</b>
<b>4</b>	<b>WIRING</b>	<b>4</b>
<b>5</b>	<b>CABLE CONNECTIONS</b>	<b>5</b>
	5.1 TERMINAL BOARD	5
	5.2 AUXILIARY MICROSWITCHES	5
	5.3 OPTIONAL POTENTIOMETER FOR ANSWER SIGNAL OF POT. B POSITION	5
<b>6</b>	<b>AUXILIARY MICROSWITCHES</b>	<b>5</b>
<b>7</b>	<b>FEEDBACK POTENTIOMETER/S</b>	<b>6</b>
<b>8</b>	<b>CONTROL STATION</b>	<b>6</b>
<b>9</b>	<b>ADJUSTMENTS</b>	<b>7</b>
	9.1 ENDSWITCHES	7
	9.2 ELECTRONIC BOARD [ONLY ON EMERGENCY]	8
<b>10</b>	<b>OPERATING</b>	<b>8</b>
<b>11</b>	<b>MAINTENANCE</b>	<b>8</b>
<b>12</b>	<b>REPLACEMENT</b>	<b>9</b>
<b>13</b>	<b>ELECTRONIC CONFIGURATION</b>	<b>9</b>
	13.1 ELECTRONIC CONFIGURATION AB1...SE2 INPUT SIGNAL 4-20 MA OR 0-10V OUTPUT SIGNAL 0-10V	10
	13.2 ELECTRONIC CONFIGURATION AB1...SE4 INPUT SIGNAL 0-10V	11
	13.3 ELECTRONIC CONFIGURATION AB1...SE5 INPUT SIGNAL 4-20 MA	12

## 1 GENERAL FEATURES

Electronic rotary gear motors of series AB1...SE have been newly conceived and specially designed to be installed on residential and industrial combustion systems.

They are particularly suitable for control and regulation of modulating disc valves, butterfly valves, dampers and other fluid regulation systems requiring control of position angle within 90°. Electronic rotary gear motors are unipolar and bidirectional with high static and maintaining torque. Analogic input signal according to current [4 ÷ 20 mA] or voltage change [0 ÷ 10 Vdc].



### WARNING

Installation, wiring, adjustment and maintenance of gear motors must be carried out exclusively by skilled and authorized service technicians. Non-proper installation, adjustment, modifications, use and maintenance may cause injuries to the staff or material damages. It is therefore necessary to respect strictly the following instructions and local prescriptions for the installation of electronic devices.

## 2 TECHNICAL DATA

Body and cover	die-cast aluminium
Nominal torque	3 ÷ 5 Nm
Maintaining torque	2,5 ÷ 3 Nm
Rotation time	15 ÷ 60 seconds for 90° at 50 Hz
Output shaft	10 mm diameter
Rotation angle	standard 90°
Installation	in any position
Fastening bore	DIN ISO 5211 – F05 and F07
Ambient temperature	- 10° ÷ + 60° C
Weight	1.7 Kg
Standard supply voltage	24 Vac / 50 - 60 Hz
On request	with trafo 115V~ up to 24 V~ with trafo 230V~ up to 24 V~
Standard input signal	4 ÷ 20 mA or
On request	0 ÷ 10 Vdc
Nominal load	4 -7 VA
Impedance input signal	250 ohm / 4 kohm
Rating of electronic contacts of endswitches and auxiliary switches	0,5 A / 48 Vdc and Vac
Enclosure	IP 54 according to IEC 529
Available potentiometer	1000 ohm
Duty cycle	continuous 100%
Cable entry	2 x Pg 13.5
Manual/Automatic operation and service switch	"Open/Stop/Closed"

### 3 INSTALLATION

- 3.1 Make sure that all operating data indicated on gear motor plate correspond to the ones of the systems.
- 3.2 When installing the gear motor make sure that there is sufficient clearance above the gear cover and that it is easily accessible in order to perform wiring and endswitches adjustment.
- 3.3 AB1...SE rotary gear motor is always supplied by the factory with standard endswitches adjustment suitable for 90° rotation angle.
- 3.4 From a frontal view the motor shaft rotates:
  - clockwise  $\curvearrowright$  [closes] by decreasing of the input signal between terminals 2- 3
  - counter clockwise  $\curvearrowleft$  [opens] by increasing of the input signal between terminals 2 -3

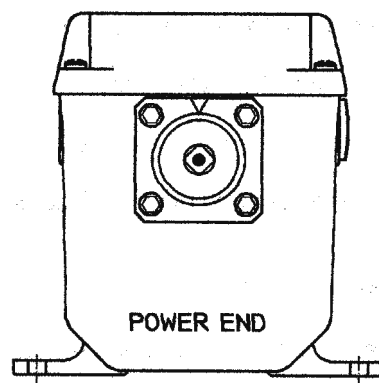

- 3.5 AB1...SE gear motor must be free to be stopped by its electronic endswitches; the installation of mechanical locks or the presence of other obstacles could damage it.
- 3.6 AB1...SE gear motor can be installed in any environment included in the range of electrical protection IP 54 and IP 65 except where acid fumes or other deteriorating vapours might attack its metal parts or where gas leaks or explosive vapours are present in the atmosphere. In environments with high salt percentage, fastening screws should be zinc or cadmium plated and should not be made of brass or stainless steel.

## 4 WIRING

4.1 After having installed AB1...SE gear motor and before fastening it mechanically to the device it has to operate, proceed with wiring and earthing.

4.2 Wiring diagrams are reported in the attached technical bulletin and on the plate inside the cover.

### 4.3 WARNING



Before servicing make sure, that power supply is disconnected by means of the two-pole-switch [phase and neutral]; in case of non-observance, damages to people and equipments may occur.

4.4 In order to accede to the internal wiring terminal board, remove the cover by loosening the 4 fastening screws.

4.5 Two threaded holes for the fitting of the conduit plugs Pg 13.5 are present on the frame of the AB1...SE gear motor.

4.6 All wires must comply with local prescriptions and, in any case, their section must be ranging between 1 and 1.5 mm<sup>2</sup>. Connection piping recommended H07V-U...G1.5 mm<sup>2</sup>.

4.7 Connection wiring diagrams show AB1...SE gear motor at end position closed [0°].

4.8 Auxiliary microswitches are single-pole double through and voltage-free.

4.9 The rating of auxiliary microswitches is 0,5 A / 48 Vdc and Vac

4.10 Make sure that power supply and system frequency correspond to the values indicated on the gear motor plate.

### 4.11 WARNING



Supply voltage of signal transmittor must be separated from the gear motor supply voltage unless the transmittor is equipped with a separator transformer to avoid short circuits.

4.12 Low-tension signalling cable [tension lower than 48V] must be laid separately from the higher-tension conduits [tension higher than 48V]. In case they are laid in a single channel, screened cables must be used.

### 4.13 WARNING



Fasten the screws by means of an electrical or manual Screwdriver, which has a torque lower than 0,5 Nm to avoid damages on the terminal box...

## 5 CABLE CONNECTIONS

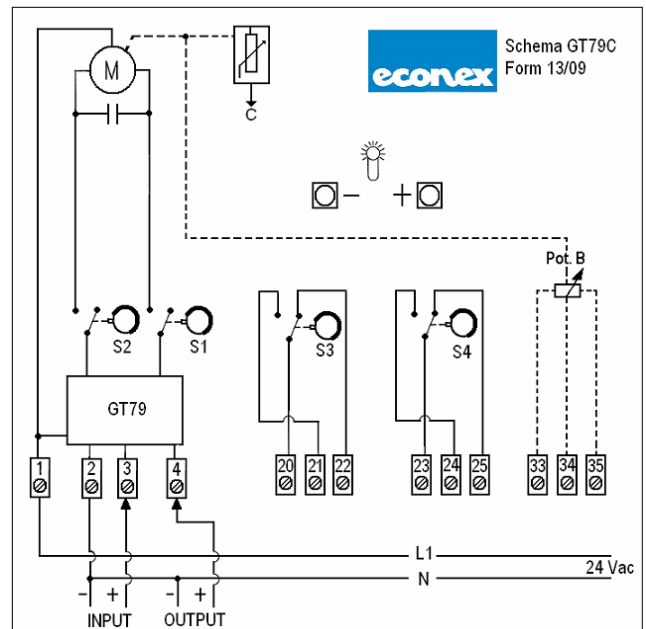
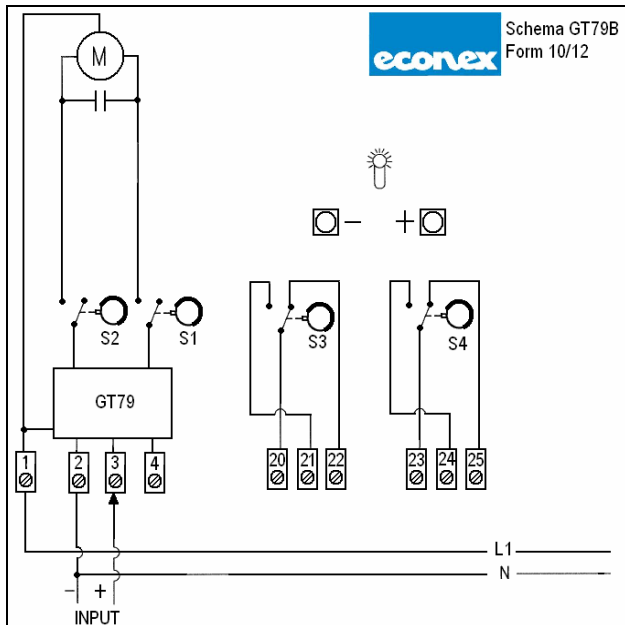

### 5.1 TERMINAL BOARD

Terminal 	earthing
Terminal 1	24 Vac / 50 – 60 Hz
Terminal 2	no tension
Terminal 3	by increasing input signal the gear motor shaft rotates counter clockwise ↺ [opens]
Terminal 16	answer signal when the gear motor reaches the position “open”
Terminal 17	answer signal when the gear motor reaches the position “closed”

### 5.2 AUXILIARY MICROSWITCHES

Terminal 20	common contact of the auxiliary microswitch S3
Terminal 21	normally open contact of the auxiliary microswitch S3
Terminal 22	normally closed contact of the auxiliary microswitch S3
Terminal 23	common contact of the auxiliary microswitch S4
Terminal 24	normally open contact of the auxiliary microswitch S4
Terminal 25	normally closed contact of the auxiliary microswitch S4

### 5.3 OPTIONAL POTENTIOMETER FOR ANSWER SIGNAL OF POT. B POSITION

Terminal 33	max. value
Terminal 34	slider
Terminal 35	min. value

## 6 AUXILIARY MICROSWITCHES

On request, AB1...SE gear motor is supplied with 2 auxiliary microswitches, which can be adjusted in any position.

Microswitches are voltage-free.

Contact rating is about 0,5 A/ 48 Vdc and Vac with Ohm load and about 1 A/250 with inductive load.

For adjusting the cams of auxiliary microswitches, proceed as for cams of endswitches as indicated in paragraph 9.1 of § 9 ADJUSTMENTS.

## 7 FEEDBACK POTENTIOMETER/S

On request, the AB1...SE gear motor can be supplied with 1 independent potentiometer [pot. B] for answer signal of the position of the gear motor.

Resistance value of the potentiometer is indicated on the identification plate.

If resistance value does not correspond to the one wished, proceed as indicated in paragraph 9.2 of **§ 9 ADJUSTMENTS**.

Power consumption is 2 W.

## 8 CONTROL STATION

- 8.1 Local control station allows the manual rotation of the gear motor.



- 8.2 AB1...SE is normally set on AUTOMATIC operation. When the gear motor is powered, a green led light between the two push buttons, flashes four times repetadly.

- 8.3 To select MANUAL operation, push both keys simultaneously for at least three seconds . On MANUAL operation , a red light will remain on .



- 8.4 Pushing the key ▼ gear motor will rotate counter clockwise ⤿ ( cam S2 control the final opening position).

- 8.5 Pushing the key ▲ gear motor will rotate clockwise ⤻ ( cam S1 control the final closing position).

- 8.6 Once setting operation is complete, push both buttons simultaneously for at least three seconds to return to automatic operation. On AUTOMATIC operation the green light will flash permanently.

- 8.7 Each time AB1...SE is turned off, it will restart always on AUTOMATIC way .

## 9 ADJUSTMENTS

### 9.1 ENDSWITCHES

As already reported in § 2 the AB1...SE electronic rotary gear motor is supplied by the factory with adjustment foreseen for a 90° rotation angle. If higher or lower than 90° rotation angles are requested, proceed as follows:

- 9.1.1 Disconnect the operating lever system of the gear motor shaft and remove the cover.
- 9.1.2 For "CLOSED" position adjustment it is necessary to operate on cam "S1".  
For "OPEN" position adjustment, it is necessary to operate on cam "S2".
- 9.1.3 For cam adjustment, use the proper "half-moon" key, supplied with the AB1...SE gear motor equipment and installed inside.
- 9.1.4 Use the key from the right side, introducing the pin into one of the holes on the sides of the blue cam of the cam involved and lever it to desired position.
- 9.1.5 If the blue cam is in a behind position, use at first the lever on its curved side to move the blue cam to a more suitable position to perform adjustment.
- 9.1.6 Cam adjustment is possible in both directions and along the whole rotation angle of the cam shaft.
- 9.1.7 Remove the key before servicing.
- 9.1.8 Run the AB1...SE gear motor for a few cycles making sure that the right cam adjustment has been achieved.
- 9.1.9 Once all adjustments have been carried out return the key inside the AB1...SE gear motor and reinstall the cover by fastening the 4 screws.
- 9.1.10 Reinstall the control lever system of the AB1...SE gear motor and test functioning of the whole system.

## 9.2 ELECTRONIC BOARD [ONLY ON EMERGENCY]

AB1...SE rotary gear motor is always supplied by the factory already with required sets and therefore any action on cams and potentiometer should be strongly avoided.

### WARNING



Potentiometer is suitable for board balancing **exclusively** and has not to be used for any different need.

- 9.2.1 Supply voltage to the gear motor.
- 9.2.2 Adjust the control device on 4 mA [or 0 Vdc] manually
- 9.2.3 Spin the motor by switching the knobs +/- up to the mechanical zero.
- 9.2.4 Calibrate the S1 cam [closing] nearly for starting point of microswitch.
- 9.2.5 Turn the shaft of potentiometer clockwise ↻ till its mechanical stop.
- 9.2.6 Adjust the control device on 6 mA [or 3 Vdc], wait for motor operation and reset it on 4 mA [or 0 Vdc] and check 0° achievement.
- 9.2.7 Whenever 0° set would not be reached, spin the shaft of potentiometer counter clockwise ↺ till 0° exactly.
- 9.2.8 Adjust the control device on 20 mA [or 10 Vdc] and check the max. opening time.
- 9.2.9 Calibrate the S2 cam nearly for starting point of microswitch.
- 9.2.10 Adjust the control device on 4 mA [or 0 Vdc], setting the motor at 0° on return.

## 10 OPERATING

After installation and adjustment of the control lever system check that switch and wiring of the circuit are correct.

Check that the AB1...SE rotary gear motor duly controls the device it is meant for.

Check that the AB1...SE rotary gear motor runs in accordance with the given manual input.

Check that the AB1...SE gear motor, the lever system and the controlled device are mechanically connected in a correct and safe way.

Check that the levers' movements occur smoothly without jamming or blocking due to other objects.

## 11 MAINTENANCE

The AB1...SE rotary gear motor does not require any particular current maintenance.

The AB1...SE gear motor does not require any lubrication because the gear mechanism is immersed in a grease bath.

Do not disassemble any internal part of the AB1...SE gear motor. In case of non-functioning, after having performed all possible checks on field, it must be returned to the factory for any possible repair.

It is not advisable to perform any repair on field.

Any replacement must be carried out by qualified technicians only.



## 12 REPLACEMENT

In case replacement of the AB1...SE gear motor is necessary, proceed as follows:

- disconnect power supply from the gear motor
- remove the gear motor's cover
- disconnect electronic wiring taking note of the cables' numeration
- remove all levers between the AB1...SE gear motor and the controlled device
- install the new AB1...SE gear motor proceeding as per the instructions given in the foregoing chapters

## 13 ELECTRONIC CONFIGURATION

The digital electronic board mounted on AR2 gear actuator enables to set various features / options, like rotation direction, resolution, type of input control signal and impedance.

### WARNING



For each model there is a specific electronic board, with its own specification in hardware and software.

The desired configuration can be obtained by setting dip-switch of the electronic board on the right or left hand side, according to the below indicated schemes.

Dip-switches are located under the paperboard panel over the horizontal board. Lift the rectangular paperboard to access the dip-switches

13.1 ELECTRONIC CONFIGURATION AB1...SE2  
 INPUT SIGNAL 4-20 MA OR 0-10V OUTPUT SIGNAL 0-10V

DIP SWITCH POSITION		
DIP SWITCH	DIP SWITCH ON LEFT OFF	DIP SWITCH ON RIGHT ON
1	Clockwise Rotation (from Power End side)	Counter-Clockwise Rotation (from Power End side)
2	Low Resolution 125 steps	High Resolution 200 steps
3	Standard setting (**) INPUT and OUTPUT always aligned	
4	Standard setting (**) INPUT and OUTPUT always aligned	
5	Input Signal 0-10 V d.c.	Input Signal 4 – 20 mA DS-6 MUST be turned ON
6	DS-6 MUST be turned OFF	N.A.

\*\* For other setting please look here below:

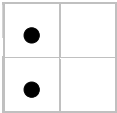
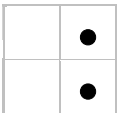
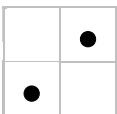
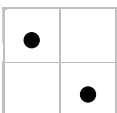
3 4	OFF		ON	STANDARD setting, Input and Output signal always aligned. For example 2V input e 2V output.
3 4	OFF		ON	REVERSE OUTPUT (only for counter-clockwise rotation). For example 2V Input signal and 8V Output Signal.
3 4	OFF		ON	DS-3 turned ON and DS-4 turned OFF. Actuator rotates for 90° with Mid-Low Input Signal. For example 0-5V with rotation of 90°.
3 4	OFF		ON	DS-3 turned OFF and DS-4 turned ON. Actuator rotates for 90° with Mid-High Input Signal. For example 5-10V with rotation of 90°.

13.2 ELECTRONIC CONFIGURATION AB1...SE4  
INPUT SIGNAL 0-10V

DIP SWITCH POSITION		
DIP SWITCH	DIP SWITCH ON LEFT OFF	DIP SWITCH ON RIGHT ON
1	Clockwise Rotation (from Power End side)	Counter-Clockwise Rotation (from Power End side)
2	Low Resolution 125 steps	High Resolution 200 steps
3	Please refer to the below reported scheme**	
4		
5	N.A.	Input Signal 0-10 V
6	N.A.	DS-6 MUST be turned ON

\*\* For special setting please look here below:

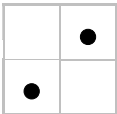
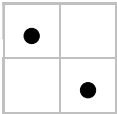
3 4	OFF		ON	DS-3 turned ON and DS-4 turned OFF. Actuator rotates for 90° with Mid-Low Input Signal. For example 0-5V with rotation of 90°.
3 4	OFF		ON	DS-3 turned OFF and DS-4 turned ON. Actuator rotates for 90° with Mid-High Input Signal. For example 5-10V with rotation of 90°.

13.3 ELECTRONIC CONFIGURATION AB1...SE5  
INPUT SIGNAL 4-20 mA

DIP SWITCH POSITION		
DIP SWITCH	DIP SWITCH ON LEFT OFF	DIP SWITCH ON RIGHT ON
1	Clockwise Rotation (from Power End side)	Counter-Clockwise Rotation (from Power End side)
2	Low Resolution 125 steps	High Resolution 200 steps
3	Please refer to the below reported scheme	
4		
5	Input Signal 0-10 V d.c.	Input Signal 4 – 20 mA DS-6 MUST be turned ON
6	Impedance at 4400 Ohm (only for Input Signal 0-10V). Always turned ON with Input Signal 4-20 mA	Impedance at 250 Ohm (only for Input Signal 0-10V).

\*\* For special setting please look here below:

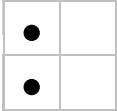
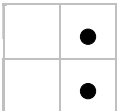
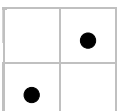
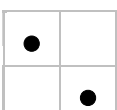
- 3  
4 OFF  ON STANDARD setting, Input and Output signal always aligned. For example 2V input e 2V output.
- 3  
4 OFF  ON REVERSE OUTPUT (only for counter-clockwise rotation). For example 2V Input signal and 8V Output Signal.
- 3  
4 OFF  ON DS-3 turned ON and DS-4 turned OFF. Actuator rotates for 90° with Mid-Low Input Signal. For example 4-12 mA with rotation of 90°.
- 3  
4 OFF  ON DS-3 turned OFF and DS-4 turned ON. Actuator rotates for 90° with Mid-High Input Signal. For example 12-20 mA with rotation of 90°.

This manual can be amended without any obligation of notice